

BLAUWE ZAAL



PDENG PROJECTS 2020

# Software Technology

TU/e

EINDHOVEN  
UNIVERSITY OF  
TECHNOLOGY

4TU.School for Technological Design, Stan Ackermans Institute offers 2-year postgraduate technological designer programmes and tracks. This institute is a joint initiative of the four technological universities of the Netherlands: Delft University of Technology, Eindhoven University of Technology, University of Twente and University of Wageningen. For more information please visit: [4tu.nl/en/](http://4tu.nl/en/)

# Software Technology - PDEng Projects 2020

- 4 **Manu Agarwal PDEng;** SmartTurkeys - A Digital Platform for Behavioral Phenotyping (DPBP)
- 6 **Nobahar Arian PDEng;** Design and Development of a Demonstrator to Facilitate a Successful Migration to the Cloud
- 8 **Enkhdavaa Batlkhagva PDEng;** Digital Twin - Virtual Hardware Simulator for a Transmission Electron Microscope
- 10 **Lkhagvadorj Battulga PDEng;** MATYSS - Modularity Assessment Tooling for Yieldstar Software
- 12 **Siemawe Kahu Bayreu PDEng;** A Formal Model for a Supervisory Controller of a Calculating Subsystem Driver - A Case Study in the Image Sensing Domain
- 14 **Yousef Fadila PDEng;** Building a Progress-tracking Application for Philips' "Three Billion Lives Improved" Vision
- 16 **Sila Güler PDEng;** Improving the Lithography Process by Automatic Control Strategy Selection Method Using Bayesian Optimization
- 18 **Anshal Joshi PDEng;** Cooling Hood Hardware Simulator
- 20 **Kavya Shiva Kumar PDEng;** Utilizing Multi-core for Dose Control Subsystem
- 22 **Mark Laane PDEng;** Intelligent Microscope III
- 24 **Konstantinos Manos PDEng;** Registration Application of the Future
- 26 **Robin Mennens PDEng;** The Philips Remote AI Streaming (PRAIS) Platform
- 28 **Hossain Muhammad Muctadir PDEng;** Model as a Service - Towards a Discovery Platform for Internet of Food
- 30 **Priyanka Patel PDEng;** Unified Messaging Control Platform
- 32 **Vahe Aristakes Pezeshkian PDEng;** Designing a Solution for Monitoring and Managing On-premise Multi-cloud Deployments
- 34 **Meram Salih PDEng;** Efficient Vacuum Development using Modeling

**PROF.DR. M.G.J. VAN DEN BRAND**  
**DR. Y. DAJSUREN PDENG**

# Model-driven Software Engineering Meets Data Science

Software has been one of the driving factors for innovations in our society in the last decades. Software creates opportunities to improve the quality of our lives, communication, etc. The COVID-19 situation shows the importance of ICT in general but of software and data in particular. We are to continue our “normal” way of working thanks to software solutions including video conferencing. The development of a vaccine for COVID-19 accelerated because of the worldwide sharing of data. Innovations are enabled by data and software and this also changes the development of high-tech systems in the Eindhoven region. Data also leads to other ways of working in agriculture and food production. By means of performing analysis of these vast amounts of data we are able to improve performance, predict maintenance, etc. It is remarkable that model-driven software engineering and data science evolve hand-in-hand and fit perfectly together. Based on results of machine learning existing models can be fine-tuned. We are on the very edge of deriving models from the data by means of advanced machine learning techniques.

Although that the importance of data and AI is already observable for a number of years, it becomes also more visible in the ST training program and final project assignments from industry. In this booklet you will find project examples of the current generation of PDEng trainees on how model-driven software development techniques are combined with data science and AI techniques. This combination leads to new ways of simulations and to test, for instance in case of ASML, software without the hardware. Thermo Fisher Scientific had a similar Digital Twin challenge, the development of a virtual hardware simulator. Philips Healthcare wanted to be able to apply AI algorithms to streaming data, the trainee developed a dedicated but powerful architecture and implementation for this. The use of “traditional” (model driven) software engineering techniques is still relevant as demonstrated by the Thermo Fisher Scientific project on the design of a modeling language for the vacuum pump. Connectivity and cloud solutions are other software engineering challenges. One of the projects at Thermo Fisher Scientific was related to cloud-based solution for monitoring. A project with Rabobank was on migration to the cloud and related security challenges. One project was on the assessment of the modularity of one of the software stacks at ASML. Philips Healthcare had also a project related to the cloud and shared services. The introduction of multi-core processors is another challenge for companies are facing, one of the ASML projects was on developing software for a multi-core processor to test the increase of processing speed. Another ASML project was related to the use of formal methods to guarantee the quality of C++ code.

It is impossible to summarize all final projects in two paragraphs, therefore we invite the reader of this booklet to go through the project descriptions. Before finalizing this foreword, we would like to express our admiration to all our trainees who have once again shown that they are able to tackle tough design problems and come up with innovative solutions that are eagerly adapted by our industrial partners in a challenging time. A few months after the start of the project all trainees were forced to work from home and had restricted access to the companies and the university. Nevertheless, all trainees have managed to finalize the project in time and with good results as you can read in the rest of this booklet, which provides a source of inspiration and shows the challenges to advanced software development. We would like to congratulate our trainees with their results and wish them a bright and successful career.

Mark van den Brand, Scientific Director  
Yanja Dajsuren, Program Director

PDEng Software Technology programme  
Eindhoven University of Technology





“Data science and A.I. have become essential technologies to modernize the animal protein and breeding industry. In this PDEng project the software architecture was designed to manage the data produced by sensors, vision, and genomics technologies to identify relationships between the observable characteristics of an individual animal (its phenotype), the collection of its genes (genotype), and the environment the animal is living in. Precise knowledge of these relationships can not only enhance the breeding processes but will also provide insights in ways to improve animal welfare. I am very pleased that Manu successfully researched and developed a novel approach to define this architecture. He will continue working on developing data-driven solutions to feed the world in a sustainable way.”

Prof.dr. Jakob de Vlieg  
Chair of the Applied Data Science (ADS) research group (TU/e)

## CHALLENGES

As this project was run under a multidisciplinary consortium, the main challenge was to understand the domain and various nuances related to the multidisciplinary project. Furthermore, the project had a PhD track after the PDEng phase, hence aligning the project goal and deliverables with the short-term and long-term point of view were also quite challenging.

## RESULTS

The results of this project are the architectural foundations of a digital platform called Digital Platform for Behavioral Phenotyping (DPBP), which is used for behavioral phenotyping in turkeys. Apart from defining the architecture, this project explored and defined various design considerations, patterns, as well as the best practices concerning data fusion, storage, governance, and metadata management. Furthermore, a technology survey report which explores different products from Microsoft Azure as well as from the open-source space for realizing the architecture are also part of the project results.

## BENEFITS

The platform enables the detection, storage, and analysis of individual phenotypes in a densely populated turkey housing facility. Furthermore, a suite of data-driven applications can be built on the platform for reaping in the benefits of individual phenotype data in the modern breeding programs.

**MANU AGARWAL PDEng**

# SmartTurkeys

## A DIGITAL PLATFORM FOR BEHAVIORAL PHENOTYPING (DPBP)

Meeting the growing global demand for protein while considering environmental sustainability is one of the biggest challenges facing the food production sector. The traditional approaches to food production are not able to keep pace with these developments, as they are facing a lot of efficiency-related issues. For example, in the context of animal protein production systems; severe health, welfare, and efficiency problems occur because of behavioral interactions among the livestock population. Technological innovations can be at the heart of solving various efficiency-related problems. For example, by leveraging the recent advances in the areas of sensing, computer vision, data engineering, and AI; we can alleviate some of the problems associated with the classical animal breeding programs.

Given this background, during this project, we aimed to define the software architecture of a digital platform, which is used for automated recording, storing, and analyzing the behavioral interaction or phenotype data on turkeys in a commercial housing facility. This architecture is based on the data platform approach as opposed to a traditional warehouse approach. Moreover, the architecture is based on the layered architectural pattern, which adheres to the Single Responsibility and Loose Coupling principles.

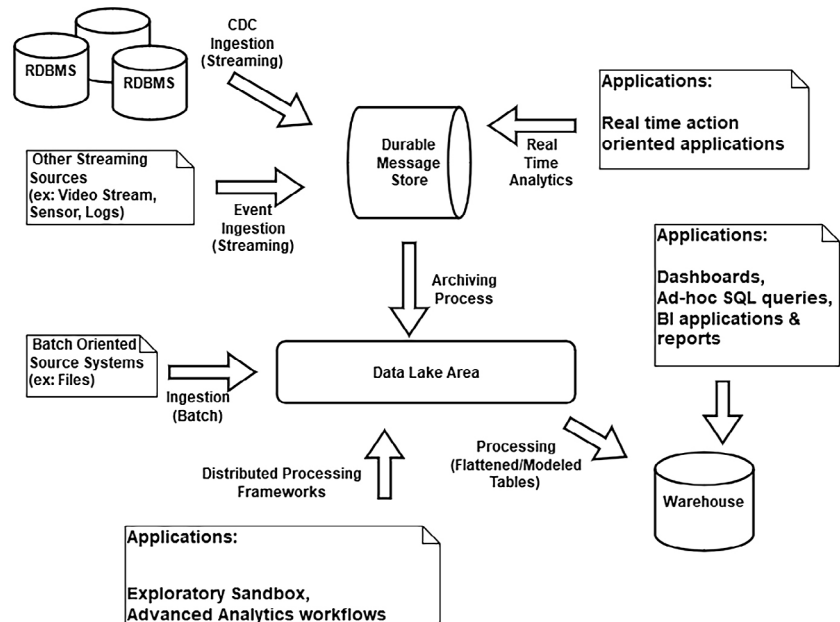

## CHALLENGES

The main challenge was to provide a solution that integrates with Rabobank's Azure infrastructure. This involved identifying relevant in-house requirements and designing a solution that adheres to them. Since this project aimed to find a solution for moving an existing application to the cloud, another challenge was to provide a compatible solution with the current implementation to reveal the possible changes.

## RESULTS

The result of this project is two prototypes: **The authentication** prototype demonstrates a solution for Azure cloud authentication/ authorization aligned with Rabobank's relevant regulations. The prototype is integrated with Rabobank's Azure cloud infrastructure. **The infrastructure provisioning** prototype performs automatic provisioning of infrastructure to the cloud aligned with Rabobank's relevant regulations. This prototype is integrated with Rabobank Azure services, particularly Azure DevOps.

## BENEFITS

The authentication prototype's design and development show how the current implementation should change to move to the cloud. Furthermore, the infrastructure provisioning presents the fundamentals of having infrastructure automation to the cloud. By presenting these prototypes, this project provides a means for Rabobank to resolve the open issues in the process of migrating to the cloud.

A portrait of a woman with dark, curly hair, smiling. She is wearing a dark patterned top with a white collar and a pearl earring. The background is blurred with warm lights.

"Nobahar provided a very good contribution to the cloud steps of the Onboarding project in the Rabobank. She achieved this on multiple parts that are involved when looking to upgrade an existing on-premise application to the Cloud. Focused on the approval process before allowing an application to start its steps towards the cloud, she helped drive a lot of the necessary steps to an approval. But foremost a new authentication and authorization design was made that could fit the on-premise as well as the cloud implementation of the application. This was supported by a working example application of how it should be implemented for the application. As well the automated provisioning of infrastructure needed and the automated deployment of this application. These accomplishments will help the team within Rabobank to set its steps towards the cloud."

Koen van de Ven  
Rabobank



**NOBAHAR ARIAN PDEng**

# Design and Development of a Demonstrator to Facilitate a Successful Migration to the Cloud

Rabobank plans to migrate one of its software systems called Global Client On Boarding (GCOB) to the Azure cloud environment. In the early stage of GCOB cloud migration, the preliminary analysis revealed open issues that must be solved so that Rabobank could move this process forward. This project was initiated to answer cloud authentication/authorization and automatic provisioning to the cloud.

Rabobank has established a set of requirements to ensure that the on-going cloud migration does not disclaim the higher level of regulations from different regulatory organizations. Consequently, a practical solution to resolve the open issues needs to recognize the relevant in-house requirements.

This project presented two demonstrators for cloud authentication/authorization and automated provisioning compatible with the relevant regulations in Rabobank:

**The authentication** prototype demonstrates a solution for Azure cloud authentication/authorization. The prototype is integrated with Rabobank's Azure cloud services, in particular Azure Active Directory. The authentication prototype is compatible with the current implementation of the GCOB. Consequently, the architecture, design, and implementation of this prototype show how the current implementation of the GCOB should change to perform the authentication/authorization in the cloud.

**The infrastructure provisioning** prototype is integrated with Rabobank Azure services, particularly Azure DevOps. This prototype performs an automated deployment of GCOB's infrastructure to the cloud. Moreover, it presents the principles of infrastructure automation in Rabobank's Azure cloud environment.

By presenting these prototypes, this project demonstrated a solution to facilitate a successful cloud migration of GCOB.

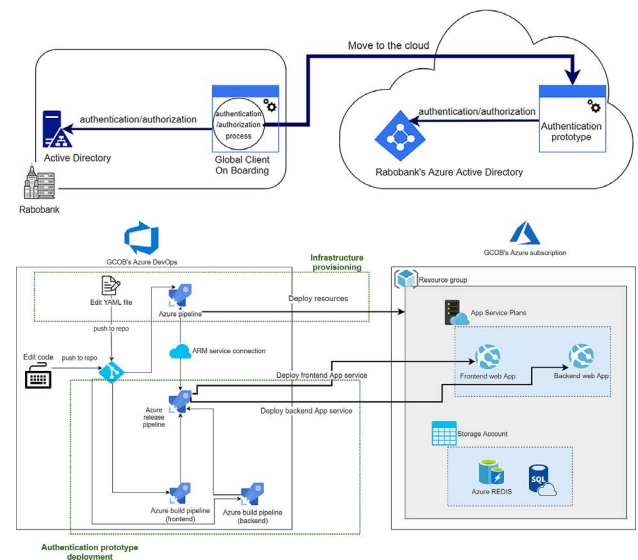

A portrait of Arjen Klomp, a man with dark hair, wearing a black polo shirt, smiling slightly. The background is a blurred indoor setting with warm lighting.

“Enkhdavaa helped us in creating a digital twin, one of our most advanced development projects. With his proactive attitude, quick understanding of our domain, and drive for success, he managed to show us the value of a Digital Twin for our development. Enkhdavaa has given many presentations of the concept and has impressed many people with the demonstrations of a working Digital Twin. We are looking forward how we can use the results of this project in a new project to further explore the possibilities for Thermo Fisher.”

Arjen Klomp  
Thermo Fisher Scientific

## CHALLENGES

In this project, working with multiple engineers from various disciplines was necessary. The first challenge was understanding the different terminologies used in multiple disciplines in the company. Another challenge occurred during the discussions with the company’s experts. The challenge was to capture the most crucial aspect of each discussion. Finally, designing and developing a fully functional prototype within a short period was another demanding task.

## RESULTS

This project’s result is the virtual hardware simulator as a proof of concept. It simulates the hardware components using 3D models. On the 3D models, motion behaviors and sensor behaviors were defined to form virtual hardware, which is nearly identical to physical hardware. The company software stack can establish a connection to the simulator for software testing purposes. From the simulator, any collisions caused by software flaws can be detected. Moreover, the simulator is capable of testing both the control level and operational level software.

## BENEFITS

The value of this project not only lies in the successful completion of the requirements but also in gaining insight into the future possibilities of the simulator that can steer the future software development processes. The project demonstrated that the simulator allows the company to initiate software test and development earlier before physical hardware is manufactured. As a result, a faster software development phase and shorter lead time for product delivery can be achieved. Moreover, the project result addressed another added value in product maintenance and services by visualizing remotely located hardware data.

# Digital Twin

## VIRTUAL HARDWARE SIMULATOR FOR A TRANSMISSION ELECTRON MICROSCOPE

Thermo Fisher Scientific develops leading-edge electron microscopes and continually improve them with new features. In the development of these new features, software plays a significant role in controlling hardware behavior. However, software development and testing require actual physical hardware. Due to this dependency, software development and testing delay if physical hardware is not manufactured.

In this project, we investigated digital twin technologies to find beneficial use cases for the company's product development. Using the digital twin technology, we created a virtual hardware simulator, a virtual version of the physical hardware on which software development and testing can take place. Additionally, the simulator is beneficial for product maintenance by visualizing the physical system's sensor data in the simulator's 3D environment. From the environment, service engineers can diagnose problems of physical hardware.

The main delivery of this project is an implemented prototype. The prototype demonstrated the project's value and set the groundwork for future development.

In the creation of the simulator, Unity Game Engine and PRESPECTIVE software were used. These technologies allow the company to build the simulator as an executable file and integrate the simulator with the company build server. Moreover, the simulator utilizes various models, namely three-dimensional (3D) models representing mechanical designs and mathematical models representing actuator behaviors.

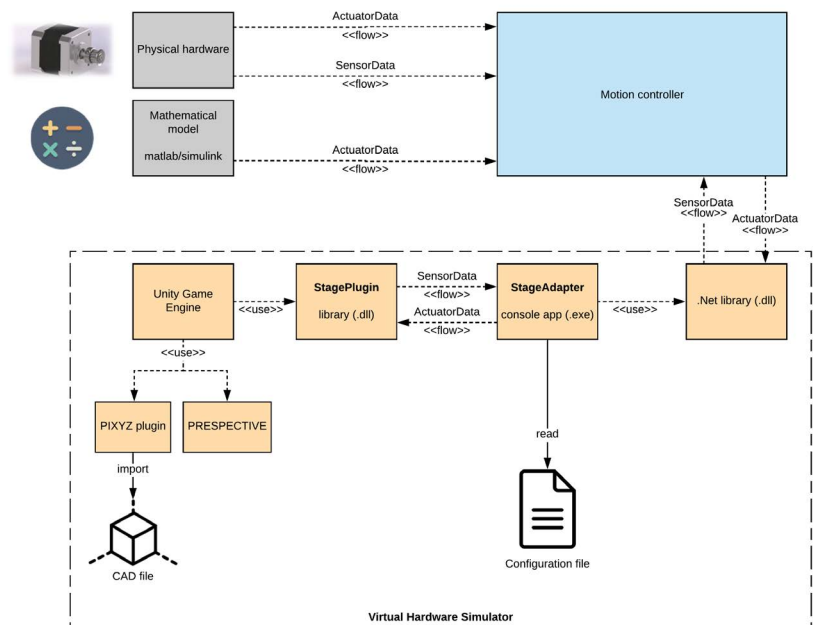

## CHALLENGES

The challenges in MATYSS were to understand the complex YieldStar software domain and prototype tools that are useful for the YieldStar software architects, managers, and YieldStar developers. The information of YieldStar software modules is imbued with multiple different artifacts. Without understanding each artifact, it is impossible to assess the modularity. Therefore, to understand each artifact in detail multiple interviews were conducted with the YieldStar software architects and designers.

## RESULTS

The results of MATYSS were two verified and validated prototype tools. First, a monitoring tool that shows the trend analysis of modularity assessments of the YieldStar software archive. Second, a prevention tool that assesses the modularity of custom software design, which is proposed by the YieldStar software designer and developers. Both tools are designed as modular as seemed useful.

## BENEFITS

MATYSS helps the YieldStar software architects, managers to monitor the quality of the YieldStar software archive. Moreover, it helps the YieldStar software developers to see the impact of how is their new design going to affect the quality of the YieldStar software archive. Moreover, MATYSS does not hinder the future changes to the YieldStar software archive semantics because its design allows a future extension, modification, and ease of maintenance.

A portrait of a young man with dark hair and glasses, wearing a grey sweater over a light-colored collared shirt. He is looking directly at the camera with a slight smile. The background is a blurred indoor setting with warm lighting.

"Lkhagvadorj was asked to develop tooling to improve the modularity of our software archive. He did an excellent job in finding his way in our organization, he collected requirements and insights from many stakeholders, and he created an extensible tool that supports modularity control. The tool helps managers and architects to monitor the quality of the software archive, and helps software designers to pinpoint modularity issues in their designs."

Ir. Christian Bakker PDEng  
ASML

LKHAGVADORJ BATTULGA PDEng

# MATYSS

## MODULARITY ASSESSMENT TOOLING FOR YIELDSTAR SOFTWARE

As the YieldStar software archive grows, the YieldStar software architects noticed that they are introducing technical debts to meet the deadlines. To tackle the technical debts, the YieldStar software architects decided to migrate from Legacy Archive to New Archive without modifying the current observable functionality of the YieldStar.

Migrating from the Legacy Archive to the New Archive is not an easy task, it is a multi-year project that requires a lot of effort from the YieldStar development teams. Therefore, to realize such a large scale project, the YieldStar software architects believe that the project should be supported by different tools. One of the supporting tools would be having a tool that assesses the modularity of the YieldStar software. Such a tool would be helpful to make a better estimation, analysis, and design.

Therefore, the Modularity Assessment Tooling for YieldStar Software (MATYSS) project was proposed. To assess the modularity of the YieldStar software archive, the definition of modularity assessment was required. Therefore, we investigated and implemented certain Key Performance Indicators (KPIs). Moreover, In the scope of MATYSS, two prototype tools were developed. First, a monitoring tool that shows the trend analysis of modularity assessments of the YieldStar software archive. Second, a prevention tool that assesses the modularity of custom software design, which is proposed by the YieldStar software designer and developers.

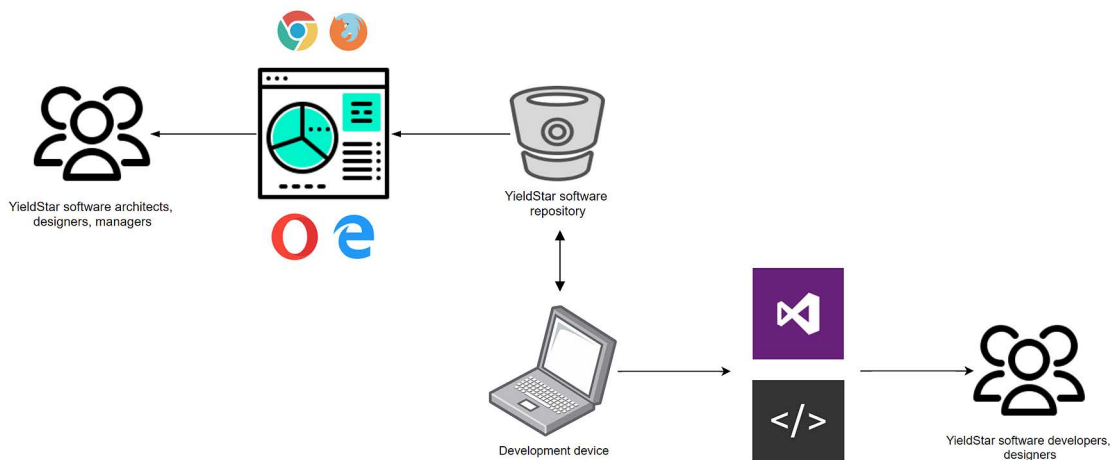



"Siemawe was challenged to create a proof of concept solution to generate and integrate code from a formally verified model. Due to little experience with these tools in the image sensor software team, he had to find out on his own how to turn it into a model. He easily found his way to the manuals, trainings, and expert team. The end result was a complete solution: integrated with other image sensor software, the diagnostics facilities of our machine and with external behavior equivalent to the current implementation. This gives us the desired confidence to start applying formal modeling, verification, and generated code integration in real production software."

Ir. W.P.A. van Heijningen  
ASML

## CHALLENGES

The first challenge faced in this project was turning the specification of the supervisory controller into a formal model due to limited experience with formal modeling tools in the software team. The second challenge was to understand the existing subsystem driver software in order to correctly integrate the auto-generated code into the production code.

## RESULTS

The results of this project are three fold:

1. Feasibility was proven by applying formal approach to model a subsystem driver control logic.
2. Feasibility was also proven for integrating auto-generated code in a subsystem driver covering the most important integration concerns, such as event subscriptions, exception propagation and error linking, and redirecting auto-generated function tracing to ASML's diagnostics facilities.
3. Extendibility/scalability was also proven by designing a multi-model solution that enables connecting and synchronizing multiple formal models.

## BENEFITS

The steps followed in this project show the complete work flow for ASML's image sensor and other subsystem drivers. The observations and findings of the project encourages software teams to start applying formal modeling in developing the supervisory controllers of the subsystem drivers in the image sensing domain and possibly other domains.

SIEMAWE KAHSU BAYREU PDEng

# A Formal Model for a Supervisory Controller of a Calculating Subsystem Driver

## A CASE STUDY IN THE IMAGE SENSING DOMAIN

ASML's image sensing embedded software group develops and maintains sensors for image alignment and image quality measurement of the optical column in the lithography machines. This group develops subsystem drivers for several image sensor types which are the workhorses that execute image sensing measurements. The control logic of these drivers are becoming more complex in terms of state behavior and their testability is to be improved. Therefore, application of innovative methods for software state behavior modeling, deployment and testing are needed to continue to deliver quality to the customer.

This project was initiated to evaluate the application of formal modeling in developing mathematically verified subsystem drivers in the image sensing domain and possibly other ASML domains. We conducted our investigation on the Transmission Image Sensor (TIS) subsystem driver control logic. The TIS subsystem driver control logic is implemented manually, and standard testing techniques are used to track down bugs. In this approach, it is impossible to completely verify the completeness and correctness of the code. With formal modeling, the verification engine mathematically and exhaustively verifies the correctness and completeness of the model. This improves the quality of the software and reduces the time spent on testing.

As part of this project, C++ code was generated from the formally verified models and integrated with other subsystem driver software modules, the lithography machine's diagnostics facilities and with external behavior equivalent to the current manual implementation.

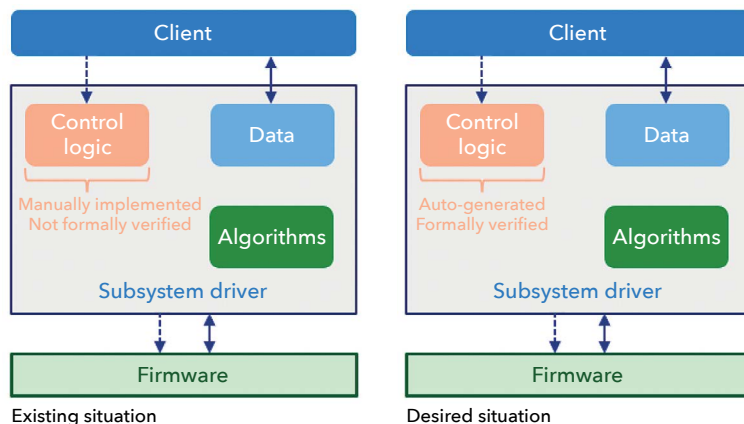

## CHALLENGES

The main challenge was the vast amount of data input and data complexity. We needed to find a way to automate mainly manual-driven processes, ensuring this became a full-swing automated process. It needed to allow higher management to make data-driven decisions towards meeting its long-term sustainability targets.

## RESULTS

A fully automated and interactive dashboard that displays Philips' historic and continuous performance towards its mission to improve the lives of 2.5 billion people by 2030 including 400 million lives in underserved communities. The outcome of this project solves a lot of challenges in the measurement process and serves both the developers and the end-users (the management).

## BENEFITS

With the right insights we can provide the right feedback at the right time to the right customer that will enable them to make the right decisions. In particular:

- Continuous insights in Philips' performance; it is essential to have an accessible feedback loop, where you're constantly thinking about what you've done and how you could be doing it better. This interactive dashboard allows that.
- Supporting data-driven decision making, ensuring Philips is able to meet its ambitious sustainability targets.
- Created a modular set-up, ensuring new businesses and/or new acquisitions can be easily incorporated.
- Ensuring all employees/managers see the same results, preventing that (outdated) Excels and emails become the source of truth.

A portrait of Siebe Trompert, a man with dark hair and a slight beard, wearing a dark blue polo shirt under a grey jacket. He is looking directly at the camera with a neutral expression.

"With the help of Yousef, we were able to create a logic end tool that provides valuable (interactive) insights on where we are improving people's lives - and - where we still have to step up. All in a manageable and easy to access dashboard. This dashboard is now used throughout Philips as a leading KPI to track the performance against our global purpose. Thank you, Yousef, for all your amazing contributions. Thanks to your skills and critical view, we were able to exceed Philips' management wildest expectations."

Siebe Trompert  
Sustainability Analyst at Royal Philips



**YOUSEF FADILA PDEng**

# Building a Progress-tracking Application for Philips' "Three Billion Lives Improved" Vision

As a leading health technology company, it is Philips' purpose to improve people's health and well-being through meaningful innovation. Philips has the aim to improve the lives of 2.5 billion people by 2030, including 400 million lives in underserved communities - making healthcare accessible for everybody at all ages.

This ambition requires an active tracking instrument to ensure we will deliver on our ambitions. With this project we aimed to build a hands-free progress-tracking application for Philips. The project was planned to replace the current calculation methodology which required significant amount of manual work with a full-automated calculation method. Creating an interactive interface/dashboard to continuously track performance allowing Philips' higher management to make data-driven decisions towards meeting its long-term targets.

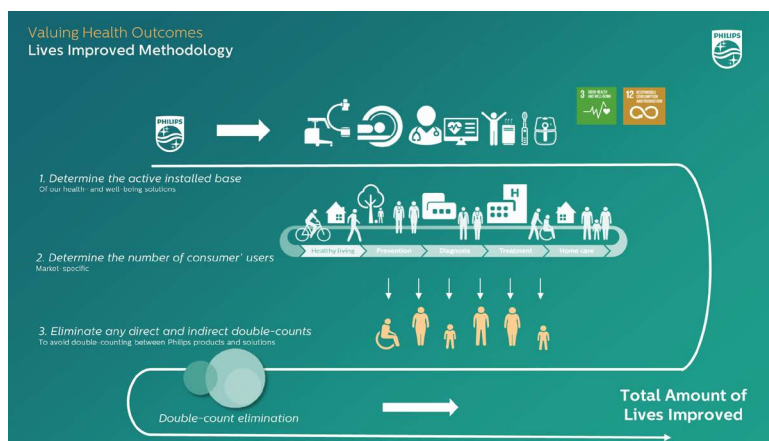



“From the start, Sila surprised us with the speed she understood our goal and requirements, and took ownership. In the end, she demonstrated how to use Bayesian optimization methods in order to create an automatic recommendation system that runs in a few hours, requires no human intervention, and achieves better results than existing manual procedures that take weeks.”

Jerzy Husakowski MSc  
Dr. Taciano Dreckmann Perez  
ASML

## CHALLENGES

The challenges in this project are understanding the complex control strategy domain and designing a Proof-Of-Concept system with the right approach for the problem domain. Unless the problem domain is understood in detail, it was impossible to design a proper solution. These challenges were overcome by arranging regular meetings with the stakeholders

- to discuss the important concepts in the domain in-depth,
- to discuss various design alternatives with their advantages and disadvantages before the design and development phase started.

## RESULTS

The system was validated against the main features with experiments. According to the experiment results:

1. The OCA system demonstrated to be capable of finding an optimal control strategy meeting the expected quality within a maximum of two hours, i.e. 98% faster than the manual selection process.
2. When the manufacturers do not have a quality constraint but they want to explore the control strategies with a time limit, the OCA system is capable of proposing an optimum control strategy that achieves on average 5.5% superior overlay performance than the manual configuration process.

## BENEFITS

The validation results conclude that developing the OCA system further and providing the lithography tools with the OCA system using Bayesian Optimization method would create a great impact on the chip manufacturers' manufacturing process. Firstly, the control strategy selection would be faster with OCA system; secondly, the overlay performance in the manufacturing process would be improved.

# Improving the Lithography Process by Automatic Control Strategy Selection Method Using Bayesian Optimization

ASML is a leading lithography tool provider in the world. The lithography tools are controlled with complex control systems to improve the manufacturing process. These control systems use various strategies that are configured by the manufacturers and ASML Customer Support in order to ensure that the chips are produced at a certain quality.

Manufacturers want to configure these control strategies as soon as possible and to start manufacturing integrated circuits in high volumes. However, the configuration is a time-consuming process because various control strategies need to be explored to select the one resulting in the expected quality.

To resolve this trade-off for the chip manufacturers, the Optimal Control Advisor (OCA) system was designed and implemented in this project as seen in Figure 1.

The system provides two main features to the manufacturers as follows:

1. An optimal control strategy search to meet an expected quality:
  - The manufacturers can set an expected quality metric and ask for the optimum control strategy resulting in the expected quality.
2. An optimal control strategy search within a specified time:
  - The manufacturers can set a time limit and explore the optimum control strategies within the specified time limit.

The optimal control strategy search was accomplished by the Bayesian Optimization method. This method proposes control strategies that promise higher quality iteratively as seen in Figure 2.

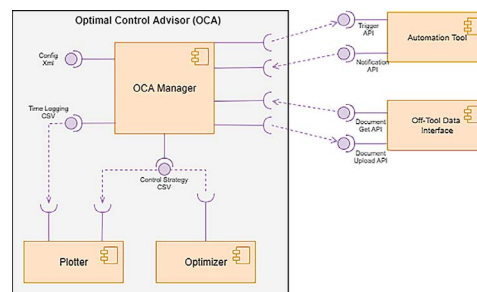

Figure 1. OCA system components

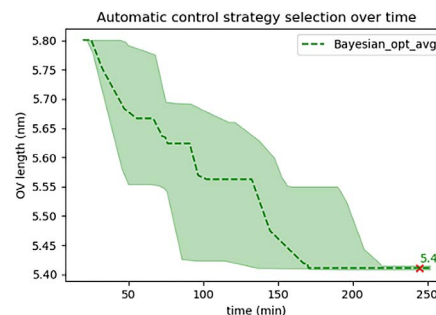

Figure 2. Iterative control strategy selection minimizing the overlay error

## CHALLENGES

The challenge in this project was to re-engineer the cooling hood hardware simulation models and extend the existing subsystem hardware simulator to provide the simulated behavior of the subsystem. The existing implementation of the subsystem hardware simulator only provides the default behavior. Therefore, the correctness of the software cannot be tested.

## RESULTS

The results demonstrate the potential of simulating subsystem hardware. The solution was successfully integrated and tested into the TWINSCAN control software. The solution includes the simulation model of the cooling hood hardware, software implementation, user-level documentation, and a deployment process to guarantee output.

## BENEFITS

The added simulation capability enabled testing capability for the cooling hood subsystem software application. The results show the increase in the code coverage for the cooling hood valve port to 100 percent. Therefore, the software developers will be able to test the cooling hood subsystem applications continuously with the development process.



"Anshal brought control theory and software together to create a simulator. The results enabled testing without hardware and helped us with early hardware/software integration."

Umut Uyumaz MSc PDEng  
ASML

**ANSHAL JOSHI PDEng**

# Cooling Hood Hardware Simulator

Lithography is an essential technology to produce semiconductor microchips. The microchips power many cutting edge technologies and digital services we use today. ASML provides advanced lithography systems (e.g. TWINSKAN) to semiconductor manufacturers. The TWINSKAN system has several subsystems, which perform a specific task in the process (e.g. wafer stage, light source). The Cooling Hood is one of the subsystems, which helps reduce the wafer deformation due to overheating during the exposure of the wafer.

The TWINSKAN machine is controlled by the complex control software. The control software is continuously tested to comply with the ASML's quality standard using different methods including testing on real hardware and testing using a simulator. The simulation approach helps the software developers to integrate the code early in the development stage. It also helps in finding and fixing the bugs early hence reduce the risk of hardware damage caused by a buggy code. The goal of this project was to introduce a hardware simulator for the cooling hood subsystem to provide software testing capability without using the real hardware and increase the code coverage.

Therefore, the solution centered on the simulation of the cooling hood hardware components (e.g. hydrogen valve) and the interaction between the simulation and the cooling hood subsystem software. The behavior of the cooling hood hardware is modeled in Simulink as a set of inputs and outputs. The hardware abstraction layer simulator is used to delegate the hardware calls to the cooling hood hardware simulator.

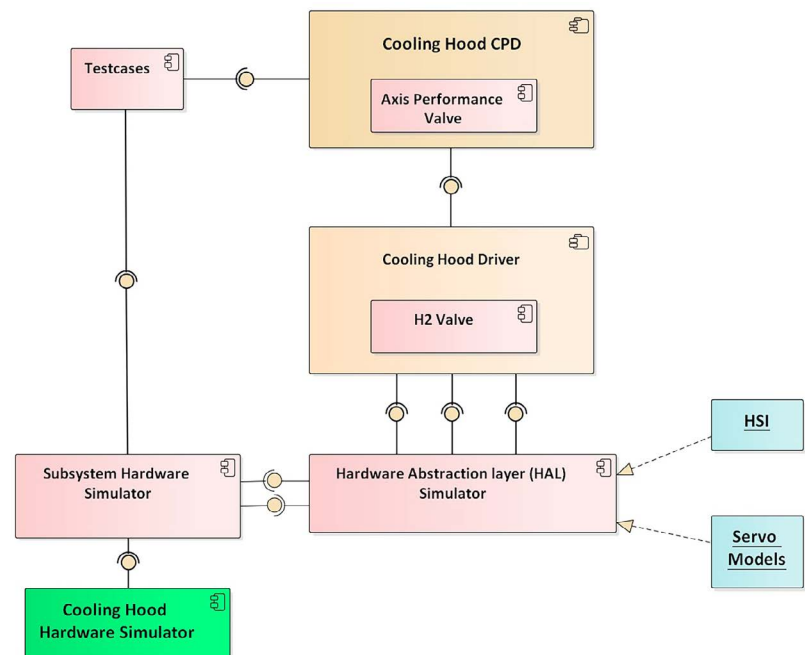



"Thanks to Kavya's hard work, dedication, and perseverance she was able to create a working prototype of a multi-core implementation. All the different solutions were evaluated with her own created benchmarking test suite and showed multi-core solutions with improved gain in timing. Now we have good insights on the impact on our driver and the challenges left when we move to a multi-core implementation."

Sjoerd te Pas MSc  
Sander van den Berg MSc  
ASML

## CHALLENGES

The challenge of this project was to understand the complex Dose Control domain and determine the performance bottlenecks, which affected the timing behavior of the subsystem. Additionally, there were very limited debugging and performance analysis capabilities that could be used for multi-core within ASML. Furthermore, the project was heavily dependent on the hardware, and the qualification of software in times of remote working was quite challenging.

## RESULTS

The immediate effects of the proposed design approach are considerable speed-up of time-critical functionalities of the subsystem, significant reduction in the time for post-processing of data, enhanced capability of the driver to process multiple concurrent requests, and availability of additional debugging facilities.

## BENEFITS

The new multi-core design enables higher resolution for the Dose Control computations. Additionally, it provides opportunities to perform proactive diagnostics. Furthermore, it reduces the termination of wafer processing caused by the deviation from timing constraints, thereby reducing the downtime for the customer.

**KAVYA SHIVA KUMAR PDEng**

# Utilizing Multi-core for Dose Control Subsystem

ASML produces advanced lithography machines that enable semiconductor manufacturers to produce electronic chips. Within these machines, the Dose Control (DC) subsystem is responsible for controlling the intensity of light falling on the wafer. It uses various sensors and actuators and performs a large number of real-time computations to achieve its functionality. With the addition of new features and stricter timing budgets in the future, the current design will reach the limits of handling large computations and cause significant variations in the timing behavior.

Although the processor of the DC subsystem is equipped with multiple cores, the software is designed to run only on a single core. The goal of this project was to determine the feasibility of transforming the existing single-core implementation of DC to a multi-core realization, thereby improving the timing behavior and the ability of DC to handle more computations. Furthermore, the modifications had to ensure that the current single-core functionality was not impacted.

In this project, a functional prototype was designed and developed for the multi-core version of the DC software after identifying the major performance bottlenecks of the DC subsystem. The performance of the multi-core prototype was measured and compared to the existing single-core design using a customized benchmark tooling developed during the course of the project. The multi-core prototype provided a significant improvement in the timing behavior, thereby demonstrating the value of performing parallel data processing in real-time systems to achieve better performance.

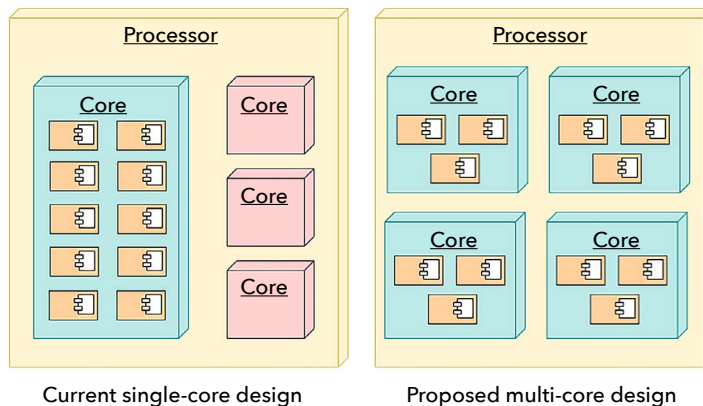

Current single-core design

Proposed multi-core design

## CHALLENGES

The challenge of this project was to identify and de-risk novel technologies that have the potential to significantly improve the ease of use of electron microscopes in the future.

On the one hand, this broad vision and the open-ended challenge was very liberating, as I had the freedom to choose my own path.

On the other hand, however, with freedom comes great responsibility - the responsibility to choose the technologies to test and the specific goals to pursue.

## RESULTS

The main results of this project are three prototypes, each one proving the feasibility of using a novel technology. Firstly, the prototype of the multilingual voice user interface proved the technical feasibility of automatically translating voice user interfaces and highlighted the limited accuracy of the approach. Secondly, the virtual reality prototype proved the feasibility of using this immersive medium for controlling the microscope. Finally, the peer-to-peer architecture prototype showed how information could be exchanged between the microscopes resiliently.

## BENEFITS

Each prototype proved the technical feasibility of one novel technology or approach, effectively de-risking it for future developers. In addition to the prototypes that serve as technical examples to future developments, this project generated numerous insights into the opportunities and challenges of using these novel technologies with electron microscopes. These insights guide future development projects in TFS, helping the company to build the next generation of electron microscopes.



*"Mark has given us significant contributions, both in code and in writing, around the (in)feasibility of various technologies at the top of the hype cycle (voice control, virtual reality, and machine2machine communication) in the context of electron microscopy. His contributions are instrumental to guide us where to focus next, and what to leave dormant for a while longer."*

Dr. Remco Schoenmakers  
Director Digital Science Technologies  
Thermo Fisher Scientific





**MARK LAANE PDEng**

# Intelligent Microscope III

Thermo Fisher Scientific is a world leader in electron microscopy and aims to retain its leadership by driving innovation in the field. Electron microscopes provide a spectacular level of detail when observing very small objects and have a wide range of uses, from semiconductor failure analysis to analysis of the novel Coronavirus. Thermo Fisher Scientific is interested in uncovering if novel technologies can be leveraged to improve the user experience and expand the user-base of electron microscopes. This is how the Intelligent Microscope project series - a project series for demonstrating the usefulness of novel technologies - originated.

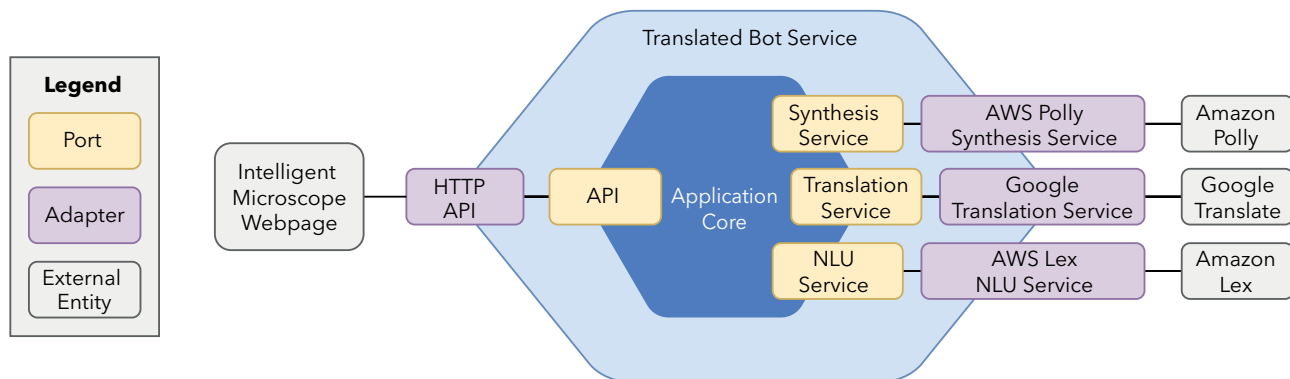
This project was a third in the Intelligent Microscope project series. In this project, I prototyped and evaluated three novel technologies: (1) multilingual voice user interface for operating the microscope in multiple languages, (2) virtual reality for interacting with the microscope in an immersive simulated environment, and (3) peer-to-peer architecture for resilient information exchange between microscopes. Each prototype proves the technical feasibility of using the technology with the electron microscopes, uncovers the opportunities and de-risks the technology by highlighting the limitations of it. The insights gathered during this project will guide future development projects in Thermo Fisher Scientific and help the company to build the next generation of electron microscopes.



A portrait of Hansuurman, a young man with dark hair, wearing a dark suit jacket over a white shirt with a patterned tie. He is looking directly at the camera with a slight smile.

“We asked a PDEng trainee to look into the topic of cancer registration and explore several of the future requirements and ways in which they can be met. Kostas took up the challenge and started energetically to dig into the matter and the complex organization behind it. And then, while looking at the future, the unexpected happened. A pandemic took us all by surprise and all of a sudden we were working from home. Microsoft Teams was all that was keeping us together. This wasn’t easy for all of us. Yet, while the pandemic is still upon us, the project comes to a close. The main new requirements have been explored. Discussions are now starting at IKNL of how we can realize the new architecture for RANK, and how to incorporate the existing 30 years of data. Many practical issues still remain, but the first exploration is done. Interesting times lie ahead, and thanks to Kostas, we had our first glance at it.”

Hansuurman  
Head of Development at IKNL

## CHALLENGES

One of the main challenges of this project was the complexity of the cancer registration domain. In order to identify potential problems and suggest solutions, a deeper understanding of healthcare concepts, as well as the operations of a complex multi-disciplinary organization was required.

## RESULTS

A context-sensitive help prototype was showcased as an alternative to the current way of offering documentation to end-users. Additionally, an event-sourcing architecture was proposed as a way to handle the complexity and challenges that the automated data delivery creates for IKNL. Finally, the feasibility of alternative ways of data validation was explored.

## BENEFITS

The final design and prototyped solutions all aim to improve the efficiency of the cancer registration process by increasing the volume of data received while limiting the appearance of errors. They can be used as a reference point to better showcase the value of the suggested solutions within the organization, to provide insight into the registration domain, and to inspire a full development project for the registration application of the future.

**KONSTANTINOS MANOS PDEng**

# Registration Application of the Future

IKNL is an organization aiming to reduce the impact of cancer. The main way to achieve this is through collecting cancer data and providing insight into the prevalence and treatment of the disease to any interested parties through scientific analysis and research. To gather this information, a registration application called RANK is currently used. The introduction of new sources of knowledge, and the constant evolution of the healthcare domain, require IKNL to advance the way of conducting cancer data registration.

One of the aspects of registration is the reception of cancer-related information from external organizations. The notifications carrying this information are not always easy to interpret and require complex business logic to transform in a format acceptable for IKNL. An event-sourcing architecture is used as part of this project to handle this complexity. Saving changes in the state of data as events provides IKNL with a way to keep track of the history of their information and to the ability to manipulate this data in different ways depending on their needs.

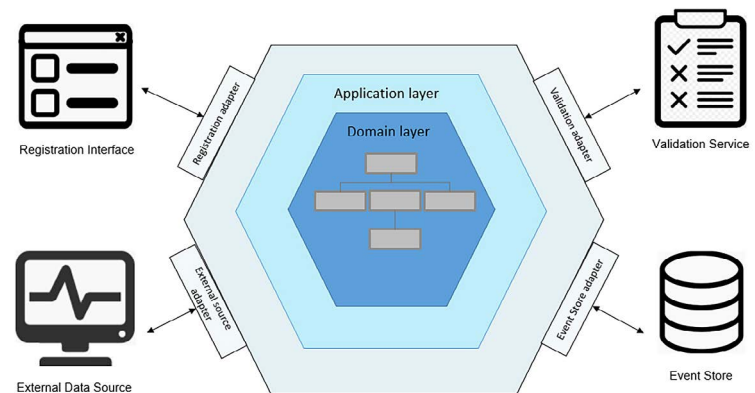

Another development of this project, is the use of a context-sensitive help feature in the registration application, to aid IKNL employees to conduct their activities with increased efficiency by providing them with the needed documentation in a more intuitive way. Additionally, an alternative to the current way data validation is realized has been proposed. The final result is a prototype that showcases the aforementioned suggestions and can be used as inspiration for future development projects.

## CHALLENGES

The main challenge in this project was to turn a preliminary proof of concept into an AI streaming platform. Finding the right balance between ease-of-use and aspects such as authentication and vendor abstraction played a major role.

## RESULTS

The Philips Remote AI Streaming (PRAIS) platform was designed and developed. PRAIS provides out-of-the-box streaming functionality and thereby enables the remote (in the cloud or on premise) execution of AI algorithms that take an audio/video/data stream as input and/or output.

## BENEFITS

As an AI co-creation platform, PRAIS benefits both Philips and its open innovation partners. In particular:

- PRAIS allows AI algorithms to run in the cloud or on premise, providing easy access to AI.
- By using PRAIS, care providers do not need complex technical knowledge and expensive infrastructure to use AI.
- PRAIS enables many valuable use cases that involve AI streaming algorithms.
- As an AI co-creation platform, PRAIS allows AI developers to easily expose their algorithms.

A portrait of Ir. Marcel Quist, a man with short brown hair and a light blue patterned shirt, smiling. The background is a warm, out-of-focus indoor setting.

“Robin turned a preliminary proof of concept into a real ‘Access to AI’ platform to stream audio and video data sources (e.g. from camera, screen share, or communication apps) from wherever in the world, to an AI algorithm wherever in the world (e.g. Microsoft, Google, and Amazon clouds, as well as dedicated Philips Healthcare AI solution components). This impacts people [...] This impacts resources [...] This impacts speed of innovation.”

Ir. Marcel Quist  
Philips Research

**ROBIN MENNENS PDEng**

# The Philips Remote AI Streaming (PRAIS) Platform

Artificial Intelligence (AI) has the potential to improve many aspects of people's lives, and thereby coincides perfectly with the Philips ambition to improve the lives of three billion people per year by 2030. Relatively new AI data sources include audio/video/data streams that deliver data in real-time and enable many new AI use cases. For example:

- Real-time analysis of Intensive Care Unit (ICU) video and vital sign data can provide faster and more accurate detection of anomalies, such as apnea in neonates.
- Speech to text transcription enables features such as real-time subtitles, automatic transcription of a doctors consult, and real-time sentiment analysis.

While the combination of AI and streaming has significant potential, the harmonized platform services at Philips do not yet provide out-of-the-box streaming functionality.

In this project, aiming to fill this technological gap, we developed the Philips Remote AI Streaming (PRAIS) platform, which enables the remote (in the cloud or on premise) execution of AI algorithms that take an audio/video/data stream as input and/or output.

We designed and implemented PRAIS based on multiple envisioned future use cases and have been able to validate twice during two collaborations. Firstly, a group of ten bachelor computer science students used PRAIS to develop demonstrators. By abstracting away the complexities of real-time streaming, PRAIS enabled the students to build complex streaming applications in just six weeks. A usability study with the students shows that PRAIS is considered easy to use. Secondly, in a collaboration with Maxima Medisch Centrum we explored how PRAIS can be used to record Neonatal Intensive Care Unit baby footage. Such recordings are used for AI research purposes.

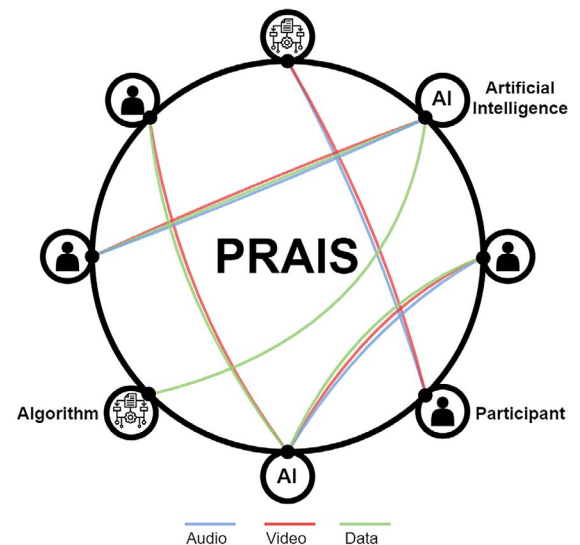



"In this PDEng project, a first, but important step has been taken towards the development of a discovery informatics platform to develop and produce food products in a sustainable way by connecting models between ecosystem partners, each having their own data, their own software and their own IP. All through the project Hossain proved to be an exceedingly well organized and problem-solving trainee. Supervising Hossain was a great pleasure!"

Prof. dr. Jakob de Vlieg  
TU/e

## CHALLENGES

In the food production domain, models are typically developed by companies for in-house usage. Therefore, these models are intellectual properties of their owners and do not follow any generally accepted standard. Designing an architecture to allow companies other than the owner to consume services from these models without having access to related artifacts (i.e., codes, executables) was the first major challenge. Moreover, dealing with the heterogeneous nature of the models was a major technical challenge.

## RESULTS

During this project, a microservice based architecture was designed and a prototype infrastructure was developed where companies can share the services of their models and use the ones shared by other companies. Using various data normalization techniques, this infrastructure offers a fixed set of interfaces to communicate with models that are heterogeneous in nature. Moreover, an intuitive web-based user interface was developed for easier consumption of the services provided by the prototype.

## BENEFITS

With the Model as a Service (MaaS) infrastructure, food production and research organizations can have access to more models that can translate to having better insights and making more informed decisions. Moreover, the MaaS prototype and the enhancement as well as research possibilities identified during its development will act as a baseline for further development of this infrastructure.

**HOSSAIN MUHAMMAD MUCTADIR PDEng**

# Model as a Service

## TOWARDS A DISCOVERY PLATFORM FOR INTERNET OF FOOD

In recent years, the world has seen unprecedented growth of population that threatens the future of food supply. The Internet of Food (INoF) consortium, which is part of Sustainable Food Initiative (SFI), aims to address the future food safety challenges using engineering solutions to make the production process more efficient and sustainable. Inter-organization collaboration can stimulate fast innovation and sustainable research processes by significantly reducing data loss as well as miscommunication. Such collaboration requires an appropriate digital infrastructure that can maintain interoperability among diverse data formats from different sources.

In the context of the food production domain, models are computational units that can calculate various properties of food products based on the information regarding the conditions, processes, and ingredients necessary to produce them. These models play a key role in the modern food production chain by automating many of the manual processes, which reduces cost and makes the processes more sustainable. Typically, these models are developed in-house and used almost exclusively by their owners. Sharing these models or their results can instigate innovation and make a significant impact on the global food safety goals.

During this project, a prototype sharing platform was developed that had the functionality to connect models from different sources and offer them as a service to external parties using modern web technologies. This prototype was designed based on microservice architecture and exploited the idea of Model as a Service (MaaS). For achieving interoperability among different data sources in the context of this project, functionalities such as dynamic model parameter mapping and on-demand unit conversion, were implemented into this prototype.

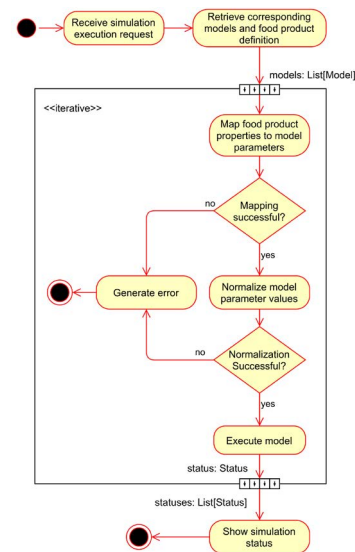
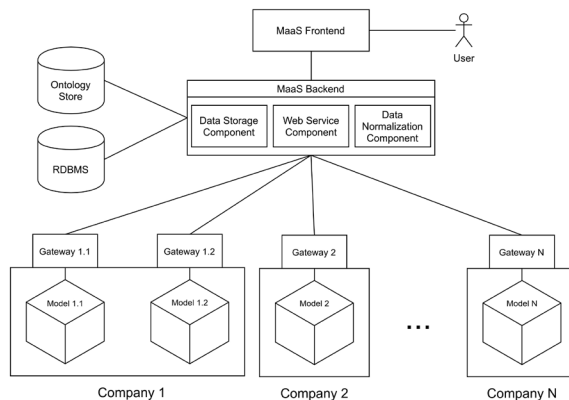

## CHALLENGES

Working in a research environment was challenging as it stimulated thinking ahead of the curve by spotting ideas and developing proof of concepts. Understanding the customer issues and their root causes, translating them into product ideas which are initially vague, and then realizing them in a streamlined way into viable solutions was interesting. Few more challenges faced were in designing the system for different applications and use cases, and understanding and applying networking protocols, technologies, and methodologies.

## RESULTS

The result of the project is a cloud-based messaging platform which can be tweaked for an on-premise implementation. The platform is equipped for low latency real-time messaging for both frontend and backend applications. Core functionalities such as real-time multimedia group messaging, optimized data synchronization, presence updates, and offline messaging are delivered. Messaging via SMS, Email, and Web Push channels are supported. Prototypes demonstrating integrations with selected AI algorithms on the multimedia data are also supported.

## BENEFITS

The cloud messaging platform exposes different types of interfaces to integrate any client web applications. For backend applications, user defined callbacks can be used through which the platform transmits real-time events. The platform also provides interfaces in order for client applications to run AI algorithms on their multimedia data. The platform is configurable and extendable, which makes it easy to add additional features and third-party services. The implementation also exhibits non-functional properties, such as modularity and interoperability.

A portrait of a woman with long dark hair, wearing a dark top, looking slightly to the right with a gentle smile. The background is blurred.

“Priyanka turned a preliminary idea of a new interfacing concept into a comprehensive new set of multimedia platform services. Interfacing between human chat conversations, multiple AI-to-knowledge-sources, and using different media channels such as email, SMS, WhatsApp. Priyanka’s platform bundles all, such that application designers are free to select the most appropriate channels suiting their use case instead of being locked in by selected vendors. Plus, for future sustainability, the platform encompasses vendor abstraction such that designers can easily switch to other vendors if these become more innovative or economically attractive.”

Zoran Stankovic  
Marcel Quist  
Philips Research



**PRIYANKA PATEL PDEng**

# Unified Messaging Control Platform

Philips is a leading health technology company with the vision of improving people's lives and well-being through meaningful innovations for healthy living, diagnosis, treatment, and home care. Philips' products and services need to be serviced to ensure top quality and performance to customers and there is always a need to continuously innovate in service delivery methods to ensure scalable delivery at all times and circumstances.

The objective of this project is to design and develop a multimedia-based messaging platform that supports messaging across different channels so that it acts as a comprehensive platform for different systems to easily incorporate messaging functionalities. System design of a multimedia messaging platform which easily integrates real-time features with web and backend applications is presented, which can be deployed on cloud or on-premise. A cloud-based system was developed and some of the high-level functionalities are real-time multimedia group messaging, presence, optimized data synchronization, and offline messaging. Communication via asynchronous channels such as SMS, Email, and Web Push are also supported.

The platform is extendable which makes it easy to integrate additional features and third-party services. A selected few AI services are integrated as prototypes to demonstrate its potential for further extension. The messaging platform developed as part of this project is tested and verified in a pilot execution with three hospitals in North America. An application named Service Connect was launched by Philips Research in order to demonstrate digitization of the remote customer support experience and the communication was facilitated by this messaging platform.

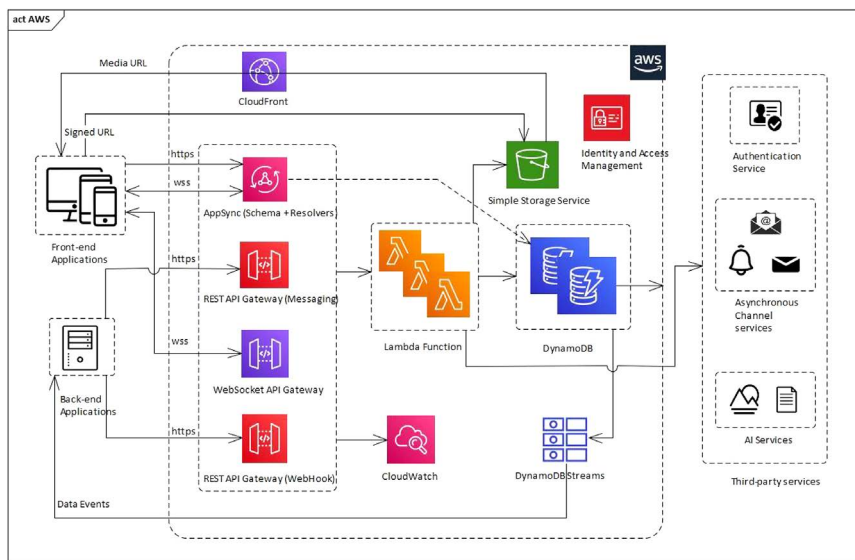



"Vahe was able to master the existing technology stack quickly and extend it with even more technology coming from the Kafka ecosystem. The design and implementation of the monitoring solution created by Vahe shows elegance, with good separation of concerns, appropriate technology choices and trade-offs, and good usage of common off the shelf components."

Ir. E. Algra PDEng

## CHALLENGES

Thermo Fisher Scientific (TFS) uses a technology stack to operate Electron Microscopes (EM) via software applications used by scientists in their laboratories. The availability and performance of the services are critical to TFS customers. Therefore, TFS needs to monitor the quality of the services and continuously innovate. The main challenge in monitoring the EM services was creating a solution that adapts to variable environment constraints and is flexible for future usage.

## RESULTS

The project delivered a Central Monitoring (CM) system that bridges the gap between the operational sites of the EMs and the Service Organization of TFS. The system defines a set of diagnostics data to monitor, aggregate, and send for further analysis using configurable components and can adapt to variable connection constraints. The diagnostics data are visualized using dashboards and are available for real-time as well as historical analysis.

## BENEFITS

Using the CM system, TFS gains insights based on metrics and events and maps them to the Service Level Agreement (SLA) parameters to continuously improve the services. The real-time analysis helps the Service Organization at TFS be responsive to an incident that might hinder the workflow of a customer, while the historical and trend analysis makes it possible to foresee and prevent incidents that might happen in the future.

VAHE ARISTAKES PEZESHKIAN PDEng

# Designing a Solution for Monitoring and Managing On-premise Multi-cloud Deployments

Scientists who research the life science, material sciences, and semiconductor fields, employ advanced equipment such as Electron Microscopes (EM) to study structures and materials at the nanoscopic scale. As the researchers contribute to the acquisition of critical knowledge, such as viral studies and vaccine development, they must have operational equipment. Thermo Fisher Scientific (TFS), as a major company serving science, has several high-end EM products to offer to the scientists and help them in conducting their experiments and research for discovering new knowledge.

TFS approach to expanding the EM solution is based on managed services delivery and a dedicated IT solution enables delivery of services via software applications. This project advances TFS in providing managed services by bringing remote observability to the IT infrastructure of the Electron Microscopes. A Central Monitoring (CM) system enables TFS to gain insight about the status of its infrastructure and in case of an incident have sufficient actionable information.

During the project, we developed a CM system using stream processing technologies in order to meet the constraints imposed by the TFS and its customers' environment. The solution provides a flexible method for extracting diagnostics data, shipping to a central destination, and incorporating them into the service procedures in order to achieve high quality of delivering EM solutions.

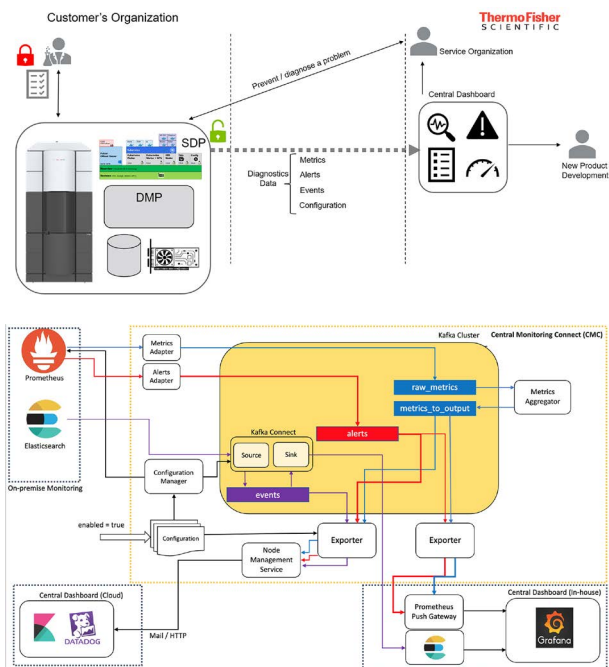

## CHALLENGES

The main challenge of this project was to translate a new vacuum concept into a model, generate code and integrate it with the rest of the TEM software into a working system. This required selecting a suitable modeling language/tool, then collaborating with people from different disciplines and multiple organizations to create the vacuum model. In addition, the new models had to be integrated with the existing codebase to produce a hybrid system.

## RESULTS

Several modeling languages and tools were prototyped and evaluated. SysML/Rhapsody was selected as the best fit for the project. Parts of the vacuum system were modeled and successfully integrated with the existing vacuum system and the rest of the TEM software codebase. The result was a fully working TEM system. SysML/Rhapsody was proven to be the right modeling abstraction for a vacuum expert.

## BENEFITS

Using an executable graphical modeling language that is intuitive to the vacuum experts will enable them to define and refine the behavior of the vacuum subsystem without depending on the software team. This leads to lower development and maintenance cost for new vacuum configurations and extensions. Moreover, this project proves that migration from the current ASD models to SysML/Rhapsody can be done using a stepwise approach.

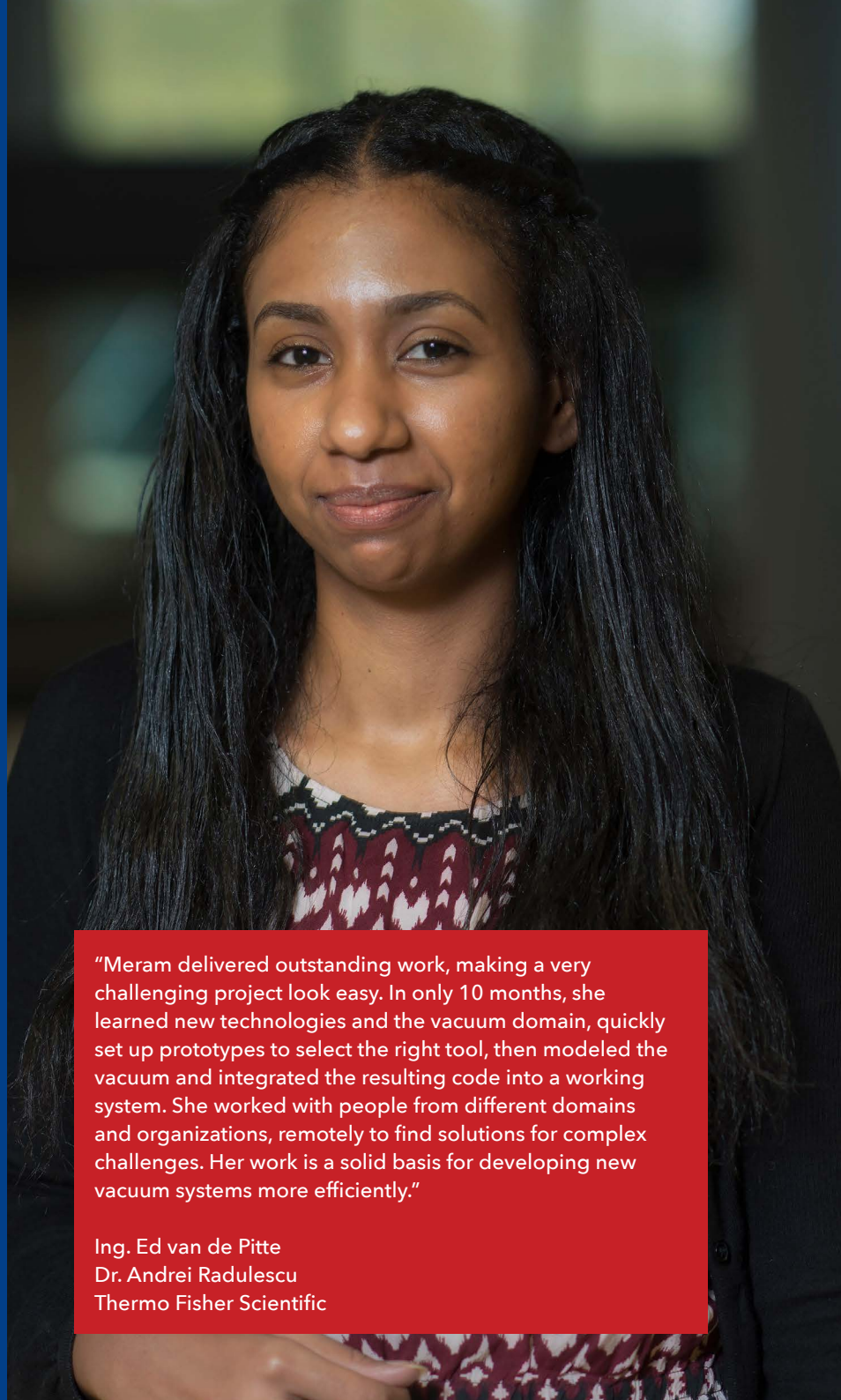

“Meram delivered outstanding work, making a very challenging project look easy. In only 10 months, she learned new technologies and the vacuum domain, quickly set up prototypes to select the right tool, then modeled the vacuum and integrated the resulting code into a working system. She worked with people from different domains and organizations, remotely to find solutions for complex challenges. Her work is a solid basis for developing new vacuum systems more efficiently.”

Ing. Ed van de Pitte  
Dr. Andrei Radulescu  
Thermo Fisher Scientific

## MERAM SALIH PDEng

# Efficient Vacuum Development using Modeling

Thermo Fisher Scientific is a global leader in designing, manufacturing, and supporting microscope technology. Thermo Fisher provides a wide range of low-, mid-, and high-end transmission electron microscopes. These microscopes have various applications in Life Sciences, Material Science, and Semiconductor Industries.

Transmission Electron Microscopes (TEM) operate at a very low vacuum pressure level to achieve atomic resolution and protect the specimen. The vacuum subsystem, which is responsible for obtaining and maintaining this low-pressure level, comes in multiple configurations to meet specific customers' requirements. The development of new vacuum configurations takes long and is costly due to the complexity of the vacuum system and the long feedback loop between the software team and the system team responsible for the development of the vacuum system.

To speed up and reduce the cost of the vacuum system development, the project investigates two improvements. Firstly, visual modeling is used to enable vacuum experts to directly define executable vacuum behavior. Vacuum experts can then refine vacuum behavior without depending on the software team, which essentially eliminates the long feedback loops across teams. The project has defined a comprehensive list of criteria for modeling tools and has compared Simulink, Dezyne, and SysML. Secondly, the vacuum behavior is decomposed into compartments, significantly reducing the vacuum system complexity. This project presents how to model the decomposed vacuum subsystem behavior using the selected language (SysML/Rhapsody) and how to integrate the code generated from the models with the existing codebase.

### Development Process using SysML/Rhapsody

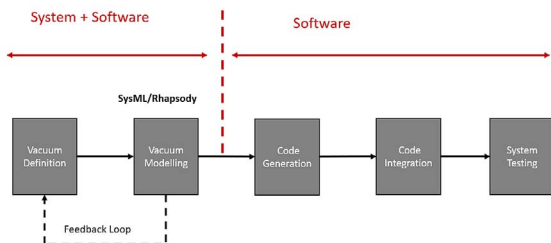

### Current Development Process

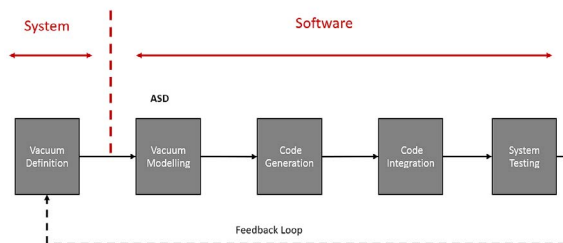

tue.nl/softwaretechnology

Follow us:



[linkedin.com/company/tue\\_pdengst](https://www.linkedin.com/company/tue_pdengst)



[facebook.com/TUePDEngST](https://www.facebook.com/TUePDEngST)



[twitter.com/tue\\_pdengst](https://twitter.com/tue_pdengst)

## CREDITS

**Edited by:** Dr. Y. Dajsuren PDEng and M.L.L. van Oorschot,  
Software Technology Programme, Eindhoven University of  
Technology

**Text:** Graduates of generation 2018 of the PDEng  
Software Technology Programme

**Photography:** Rien Meulman

**Production:** Communication Expertise Centre,  
Eindhoven University of Technology

**Design:** Grefo Prepress

**Printing:** De Digitale Drukker

**Manu Agarwal PDEng;** SmartTurkeys - A Digital Platform for Behavioral Phenotyping (DPBP) ■ **Nobahar Arian PDEng;** Design and Development of a Demonstrator to Facilitate a Successful Migration to the Cloud ■ **Enkhdavaa Batlkhagva PDEng;** Digital Twin - Virtual Hardware Simulator for a Transmission Electron Microscope ■ **Lkhagvadorj Battulga PDEng;** MATYSS - Modularity Assessment Tooling for Yieldstar Software ■ **Siemawe Kahsu Bayreu PDEng;** A Formal Model for a Supervisory Controller of a Calculating Subsystem Driver - A Case Study in the Image Sensing Domain ■ **Yousef Fadila PDEng;** Building a Progress-tracking Application for Philips' "Three Billion Lives Improved" Vision ■ **Sila Güler PDEng;** Improving the Lithography Process by Automatic Control Strategy Selection Method Using Bayesian Optimization ■ **Anshal Joshi PDEng;** Cooling Hood Hardware Simulator ■ **Kavya Shiva Kumar PDEng;** Utilizing Multi-core for Dose Control Subsystem ■ **Mark Laane PDEng;** Intelligent Microscope III ■ **Konstantinos Manos PDEng;** Registration Application of the Future ■ **Robin Mennens PDEng;** The Philips Remote AI Streaming (PRAIS) Platform ■ **Hossain Muhammad Muctadir PDEng;** Model as a Service - Towards a Discovery Platform for Internet of Food ■ **Priyanka Patel PDEng;** Unified Messaging Control Platform ■ **Vahe Aristakes Pezeshkian PDEng;** Designing a Solution for Monitoring and Managing On-premise Multi-cloud Deployments ■ **Meram Salih PDEng;** Efficient Vacuum Development using Modeling

The Software Technology PDEng (Professional Doctorate in Engineering) degree programme is an accredited and prestigious two-year doctorate-level engineering degree programme. During this programme trainees focus on strengthening their technical and non-technical competencies related to the effective and efficient design and development of software for resource constrained and intelligent software intensive systems in an industrial setting. During the programme our PDEng trainees focus on systems architecting and designing software for software intensive systems in multiple application domains for the High Tech Industry.

**The programme is provided by the Department of Mathematics and Computer Science of Eindhoven University of Technology in the context of the 4TU.School for Technological Design, Stan Ackermans Institute.**

For more information, visit our website:

[tue.nl/softwaretechnology](https://tue.nl/softwaretechnology)